

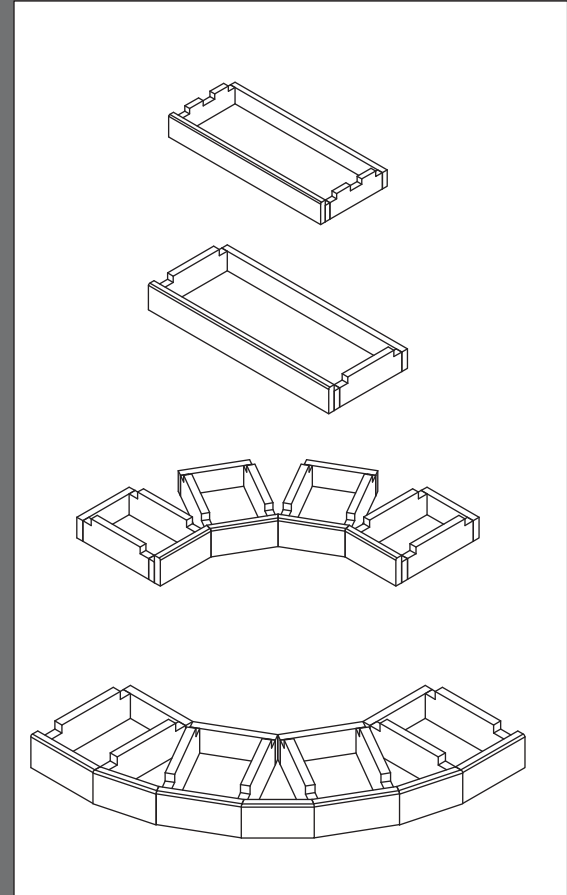

## ASSEMBLY INSTRUCTIONS



### FOR KIT RACKS:

- BASE MOULD BIN 16, 24, 32
- BASE MOULD IB 16, 32
- BASE MOULD CORNER (INSIDE)
- BASE MOULD CORNER (OUTSIDE)

# INTRODUCTION

Thank you for purchasing a **KIT RACK** by **Genuine Cellars**.  
The following instructions will help you assemble kits:

- BASE MOULD BIN 16
- BASE MOULD IB 16
- BASE MOULD CORNER (inside)
- BASE MOULD CORNER (outside)

The same instructions may be used to assemble kits:

- BASE MOULD BIN 24
- BASE MOULD BIN 32
- BASE MOULD IB 32

**Please study the instructions carefully prior to starting the assembly.**

BASE MOULD BIN 16

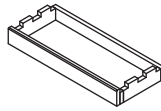

BASE MOULD IB 16

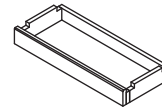

BASE MOULD CORNER (inside)

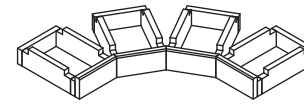

BASE MOULD BIN 24

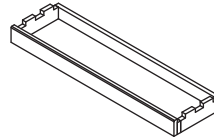

BASE MOULD IB 32

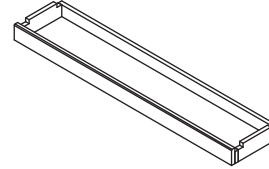

BASE MOULD CORNER (outside)

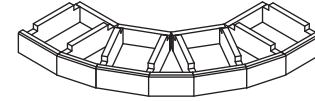

BASE MOULD BIN 32

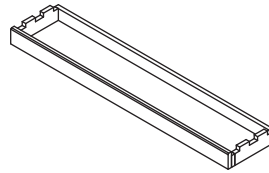

# COMPONENTS

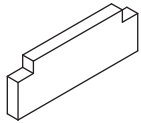

**IB BASE SIDE**  
With 2 notches

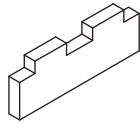

**BIN BASE SIDE**  
With 3 notches

**BASE BLOCK**

- Sizes:
- 4 3/8"
  - 16"
  - 24"
  - 32"

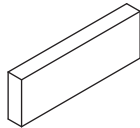

**BASE MOULDING**

- Sizes:
- 16"
  - 24"
  - 32"

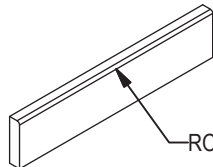

ROUNDED EDGE

**NOTE:**

Base moulding for the BASE MOULD CORNERS have mitered ends to facilitate assembly of the curved corners.

KIT NUMBER	COMPONENT			
	IB BASE SIDE	BIN BASE SIDE	BASE BLOCK	BASE MOULDING
BASE MOULD IB 16	2	N/A	2	1
BASE MOULD IB 32	2	N/A	2	1
BASE MOULD BIN 16	N/A	2	2	1
BASE MOULD BIN 24	N/A	2	2	1
BASE MOULD BIN 32	N/A	2	2	1
BASE MOULD CORNER (Outside)	2	N/A	8	7
BASE MOULD CORNER (Inside)	2	N/A	8	4

# HARDWARE

The following hardware is included in all kits:

**18 GAUGE BRAD NAILS  
(3 SLEEVES)**

# TOOLS REQUIRED

The following tools are required  
(NOT INCLUDED):

**NAIL GUN**  
(with appropriate air compressor  
or electric nailer)  
18 gauge brand nails (supplied)

**WOOD  
GLUE**

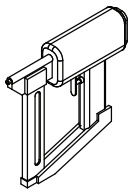

**IMPORTANT!**

**Always follow the manufacturer's instructions on how to use the nail gun to prevent injury. Genuine Cellars is not liable for any injury incurred by any power or hand tool used to assemble the kit.**

## ASSEMBLY - BASE MOULD BIN & IB

**STEP 1** APPLY GLUE TO THE ENDS OF THE BASE

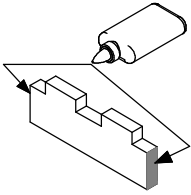

BIN BASE SIDE

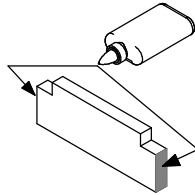

IB BASE SIDE

\*Apply enough glue so that it will not run when the pieces are nailed together

**STEP 2** NAIL BASE BLOCKS TO BASE SIDES

3 NAILS PER CONNECTION

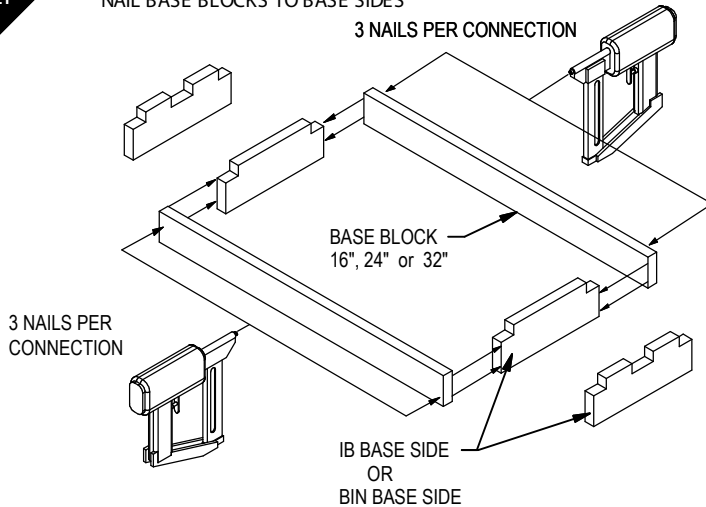

**STEP 4** ATTACHING BASE MOULD BIN TO BINS AND BASE MOULD IB TO IB RACKS

BIN 16 32

IB 16 32

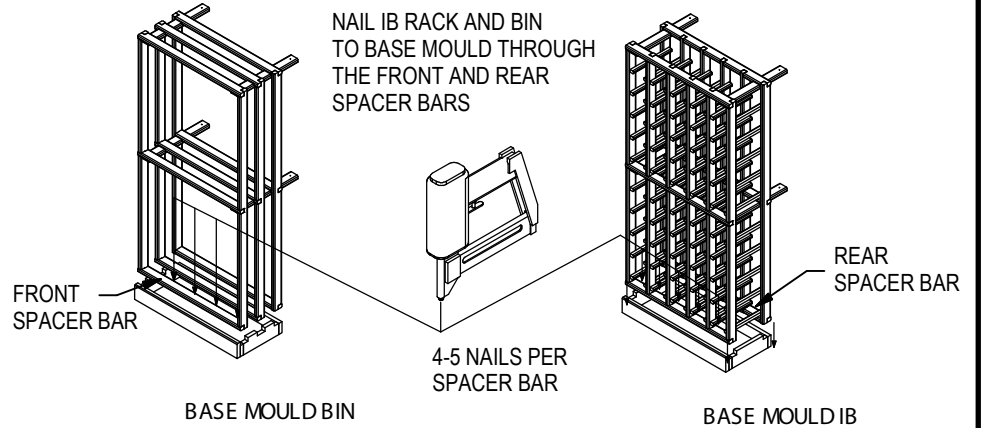

## ASSEMBLY - BASE MOULD CORNER (Inside & Outside)

**STEP 1** APPLY GLUE TO BASE SIDES

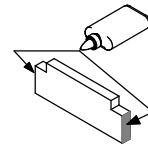

IB BASE SIDE

**STEP 2** NAIL BASE BLOCKS TO BASE SIDES

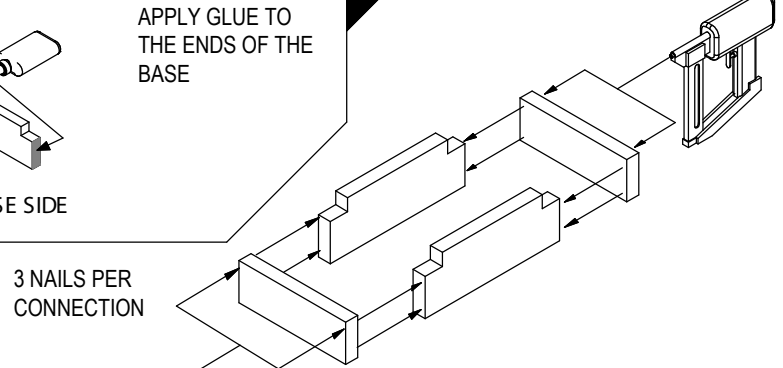

**STEP 3** ATTACH BASE MOULD TO ASSEMBLY

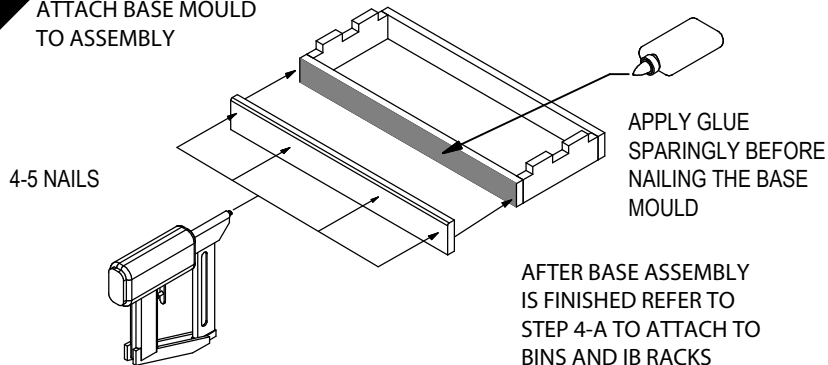

**STEP 3**

ATTACH BASE MOULD TO BASE ASSEMBLY  
(DESCRIBED SEPARATELY FOR EACH  
INSIDE AND OUTSIDE CURVED CORNER)

**A**

BASE MOULD CORNER (INSIDE) ASSEMBLY

APPLY GLUE  
SPARINGLY BEFORE  
NAILING THE BASE  
MOULD

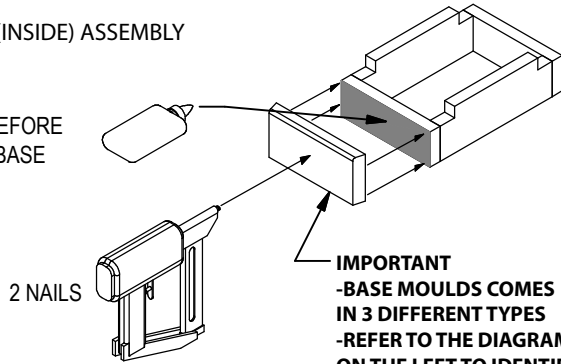

2 NAILS

**IMPORTANT**  
-BASE MOULDS COMES  
IN 3 DIFFERENT TYPES  
-REFER TO THE DIAGRAM  
ON THE LEFT TO IDENTIFY  
EACH BASE MOULD  
-ATTACH ONE OF THESE  
TO EACH BASE ASSEMBLY

TOP VIEW

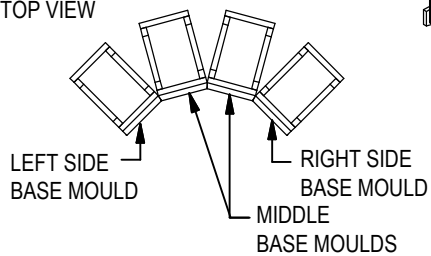

ONCE BASE MOULDS ARE ATTACHED  
REFER TO STEP 4-B FOR ATTACHING  
BASE ASSEMBLY TO CURVE CORNER KIT

**STEP 4**

ATTACHING BASE MOULD CORNER TO  
CURVED CORNER KIT (INSIDE & OUTSIDE)

CURVED CORNER  
KIT (INSIDE)

REAR  
SPACER BARS

FRONT  
SPACER BARS

2-3 NAILS PER  
SPACER BAR

NAIL CURVED CORNER  
TO BASE MOULD THROUGH  
THE FRONT AND REAR  
SPACER BARS

CURVED CORNER  
KIT (OUTSIDE)

2 - 3 NAILS  
PER SPACER BARS

FRONT  
SPACER BARS

ATTACH THE INDIVIDUAL  
BASE MOULD ASSEMBLIES  
FIRST

2 - 3 NAILS  
PER CONNECTION

NAIL ANGLED BASE MOULDS  
TO THE BASE ASSEMBLY  
AT AN ANGLE

**STEP 3**

BASE MOULD CORNER (OUTSIDE) ASSEMBLY

**B**

APPLY GLUE  
SPARINGLY BEFORE  
NAILING THE BASE  
MOULD

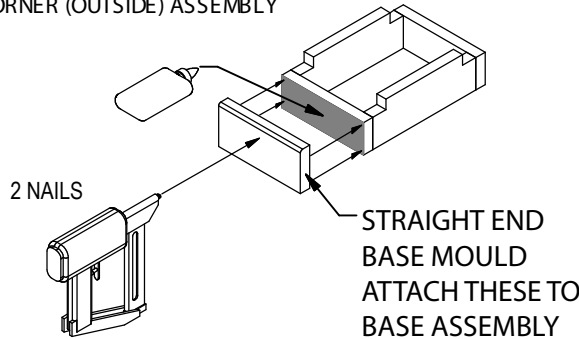

2 NAILS

STRAIGHT END  
BASE MOULD  
ATTACH THESE TO  
BASE ASSEMBLY

TOP VIEW

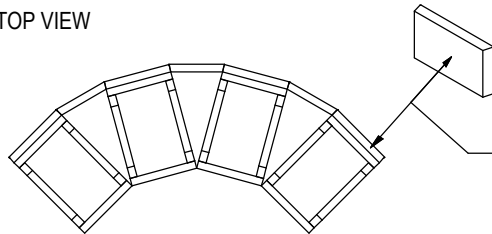

ONCE BASE MOULDS ARE ATTACHED  
TO BASE MOULD ASSEMBLY  
REFER TO STEP 4-B FOR ATTACHING  
BASE MOULD ASSEMBLY TO CURVE CORNER KIT

ANGLED END  
BASE MOULD  
-DO NOT ATTACH THESE  
BASE MOULDS UNTIL  
THE WHOLE BASE  
ASSEMBLY IS ATTACHED  
TO THE CURVED  
CORNER

