

ELITE KIT RACK ASSEMBLY INSTRUCTION

Thank you for purchasing Elite Kit Rack by Genuine Cellars. The following instructions will help you assemble the 750ml 6 COLUMN 1/2 HEIGHT RACK. The same procedure can be applied to the following kits shown.

Please study the instructions carefully prior to starting the assembly.

HARDWARE

The following hardware is included in all kits:
(QUANTITY WILL VARY, DEPENDING ON KIT.)

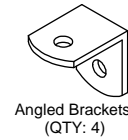
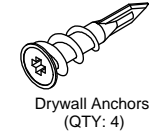

750ml 6 COLUMN 1/2 HEIGHT RACK

750ml 9 COLUMN 1/2 HEIGHT RACK

750ml TASTING TABLE

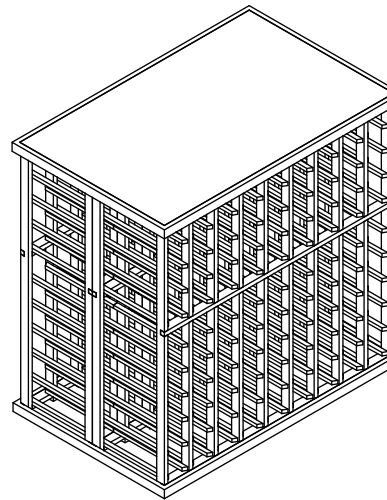
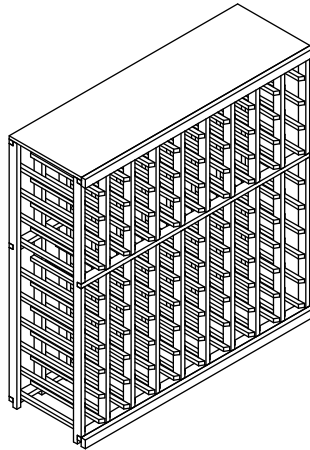
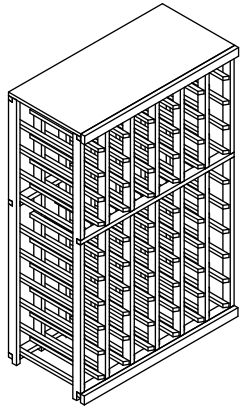

TOOLS REQUIRED

The following tools are required (NOT INCLUDED):

IMPORTANT!

Always follow the manufacturer's instructions on how to use the nail gun, to prevent injury. Genuine Cellars is not liable for any injury incurred while assembling the kit.

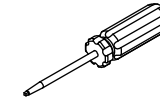
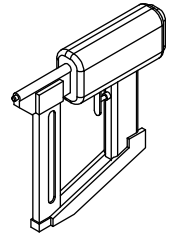

Robertson Screwdrivers #6 & #8 (Square Head)

We Recommend A 21 Gauge Nail Gun
(Use 21 gauge brand nails, with appropriate air compressor or electric nailer set to 80psi, to prevent splitting)

COMPONENTS

The following components are included in the 750ml 6 COLUMN 1/2 HEIGHT RACK.
(COMPONENTS WILL VARY IN QUANTITY AND SIZE, DEPENDING ON KIT.)

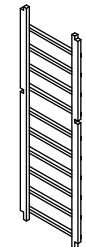

1 - Left Ladder 1034 (QTY: 1)

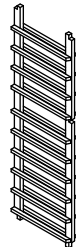

2 - Middle Ladder 1034 (QTY: 5)

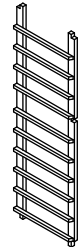

3 - Right Ladder 1034 (QTY: 1)

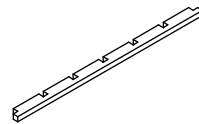

4a - Front Spacer Bars 689 (QTY: 3)

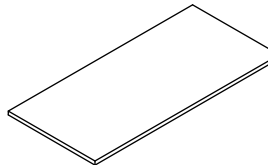

5a - Counter Top 689 (QTY: 1)

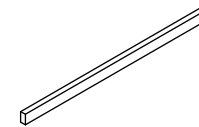

6 - Base Mould 689 (QTY: 1)

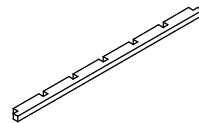

4b - Back Spacer Bars 689 (QTY: 3)

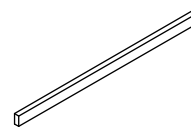

5b - Counter Nosing 689 (QTY: 1)

STEP 1

Starting from the back of the rack. Place the ladders on flat, soft surface, so not to damage front of rack. Space the ladders accordingly. **(Note: Ensure proper placement of ladders, and bottoms are all in same direction as shown.)**

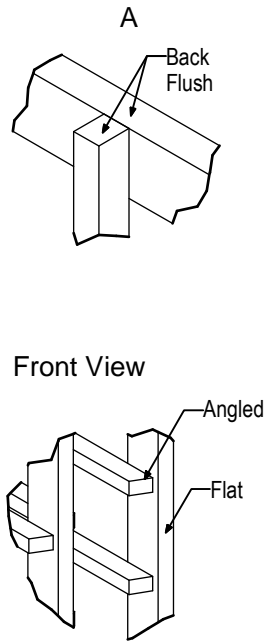
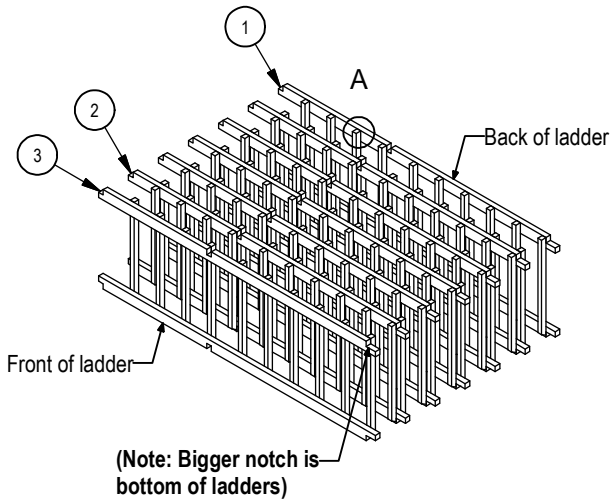

STEP 2

From the bottom and working your way up, place the back spacer bars (4b) according to the ladder notches. Make sure to carefully interlock the spacer bars to the ladders.

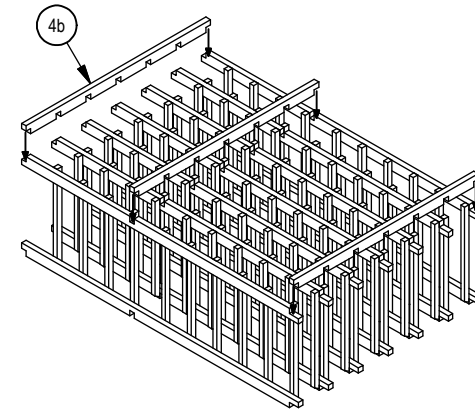

STEP 3

Once spacer bars are properly placed. Start from the bottom of the rack, firmly apply pressure to lock in the joint. Then apply two nails with a nail-gun, to each joint. Remember to firmly lock in each joint.

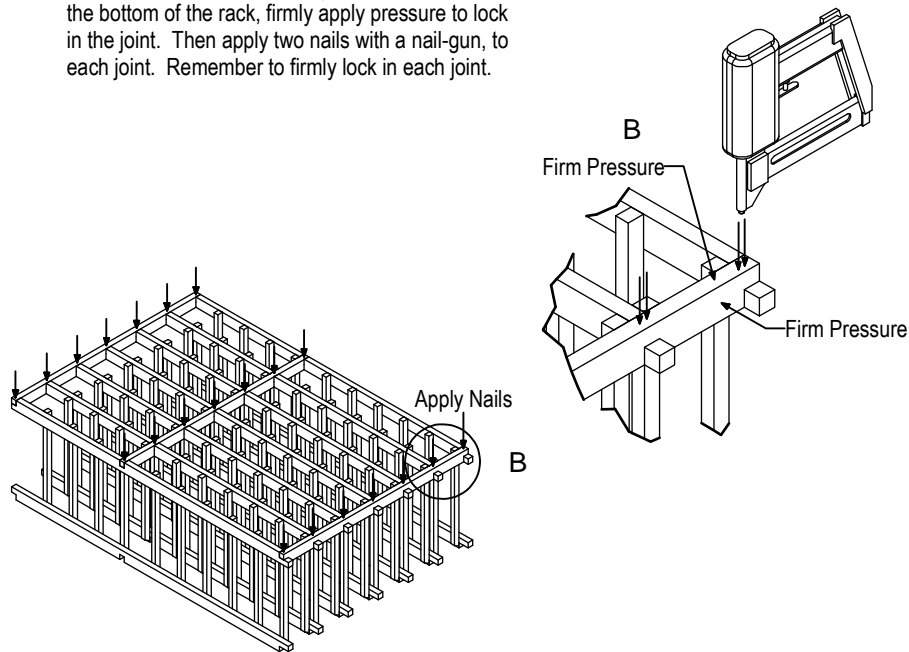

STEP 4

While backs are still facing up, screw the angled brackets to the back spacer bars as shown.

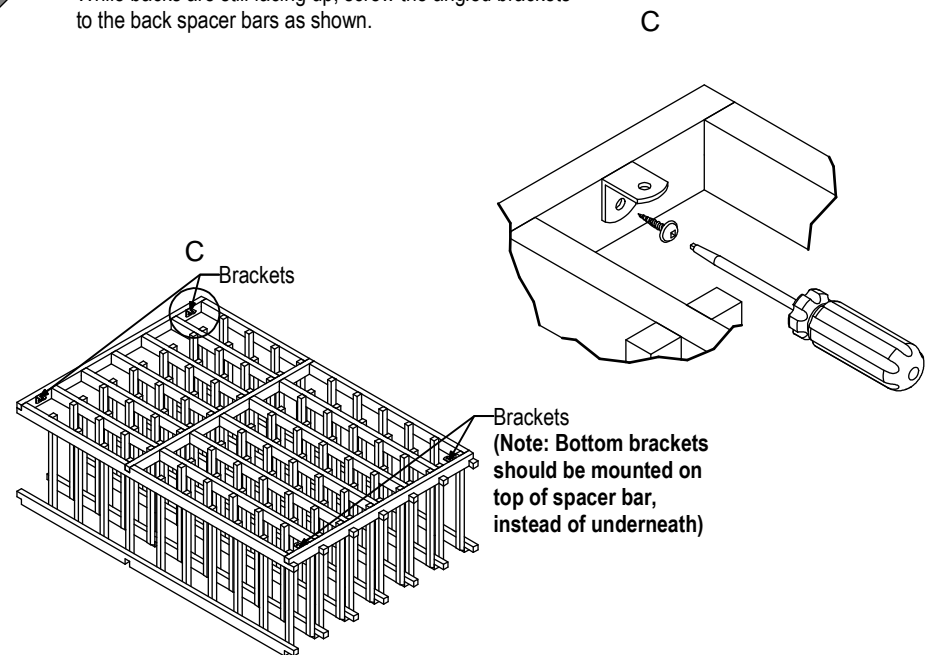

STEP 5

With the help of another person, turn the rack so the back is on the floor, and the front is facing up. Starting from bottom up, place the front spacer bars (4a) according to the ladder notches. Make sure to carefully interlock the spacer bars to the ladders.

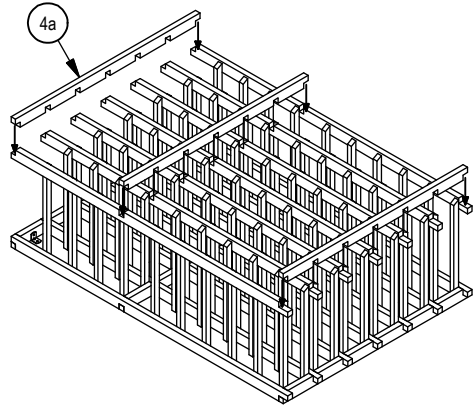

STEP 6

From the front and bottom of the rack, firmly apply pressure to lock in the joint. Then apply two nails with a nail-gun, to each joint. Remember to firmly lock in each joint.

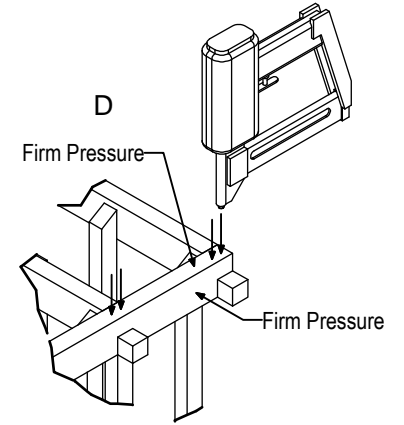
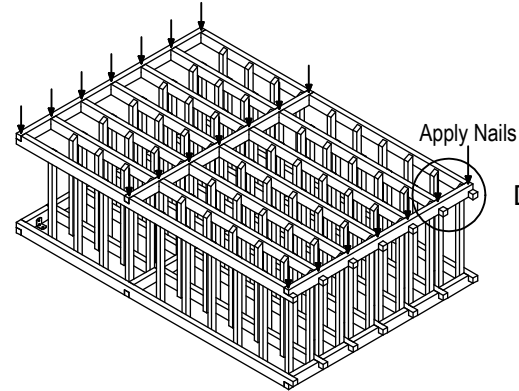

STEP 7

To apply the counter top (5a), stand the rack upright. Flush the counter top to the back, left and right side of the rack. Apply pressure to the top of the counter. Nailing from underneath, apply nails through the front and back spacer bars, into the counter top.

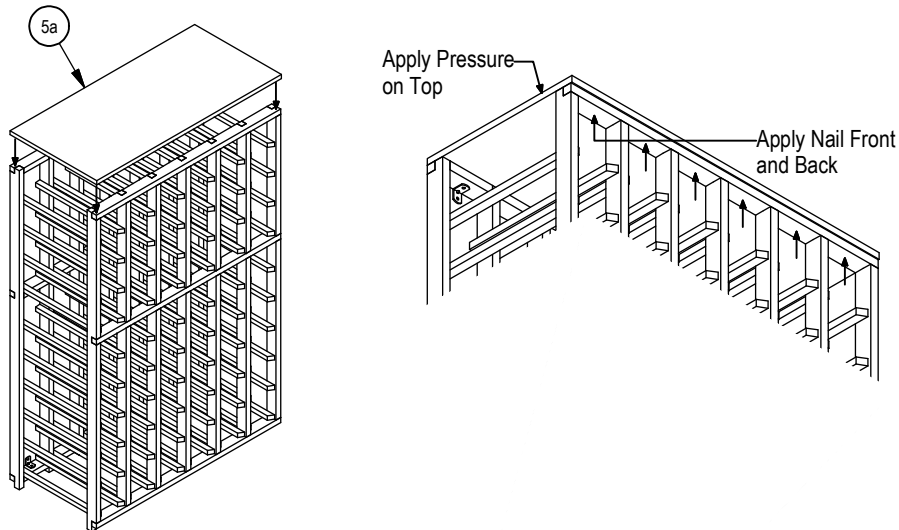

STEP 8

To finish the 750ml 1/2 height rack, apply the base mould (6) as shown. Applying counter top nosing (5b) there are 2 options. Option A, or nosing can be left off.

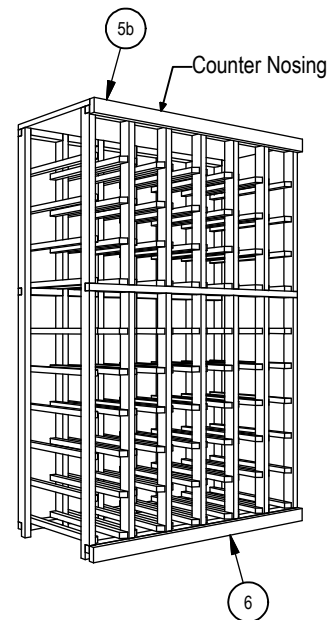

Nosing Sample A

